

IMPORTANT

SAFETY PRECAUTIONS

- To reduce the risk of death, personal injury or property damage from fire, electric shock, falling parts, cuts/abrasions, and other hazards, read all warnings and instructions included with and on the fixture box and all fixture labels.
- Before installing, servicing, or performing routine maintenance upon this equipment, follow these general precautions.
- Commercial installation, service and maintenance of luminaires should be performed by a qualified licensed electrician.
- For the installation: If you are unsure about the installation or maintenance of the luminaires, consult a qualified licensed electrician and check your local electrical code.
- To prevent wiring damage or abrasion, do not expose wiring to edges of sheet metal or other sharp objects.
- Do not make or alter any open holes in an enclosure of wiring or electrical components during kit installation.

INSTALLATION NOTE

- Turn off electrical power at fuse or circuit breaker box before wiring fixture to the power supply.
- Turn off the power when you perform any maintenance.
- Verify that supply voltage is correct by comparing it with the luminaire label information.
- All wiring connections should be capped with UL approved wire connectors.

WARNING

- Avoid direct eye exposure to the light source while it is on.
- Account for small parts and destroy packing material, as these may be hazardous to children.
- Risk of burn. Disconnect power and allow fixture to cool before handing fixture.

WIRING

Verify input AC voltage before connect. If present, the 12v AUX supply is only for the optional sensor/control.

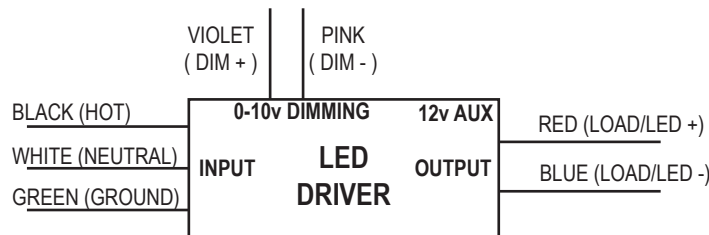

PREPARATION

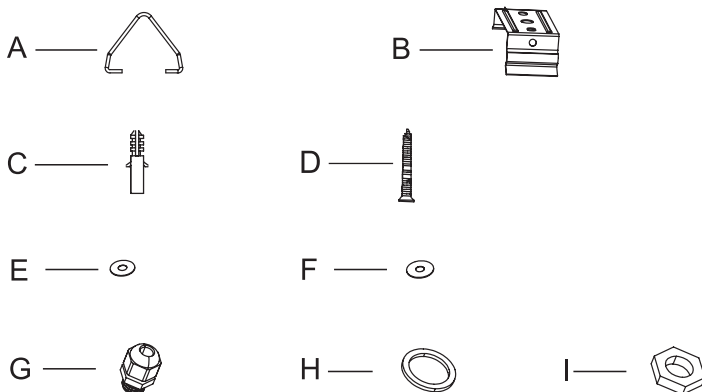

PART	Part Description	QTY	QTY
		FVTB/2-2D FVTB/2-4D	FVTB/2-8D
A	V-hook for chain mounting	2	3
B	Mounting Bracket	2	3
C	Plastic anchors	2	3
D	Mounting Screw	2	3
E	Metal washer	2	3
F	Rubber washer	2	3
G	Waterproof connector	1	1
H	Rubber sealing ring	1	1
I	Nut for waterproof connector	1	1



CCT and Wattage Dip Switch

CCT and Wattage selectable with a dip switch, on selected models.

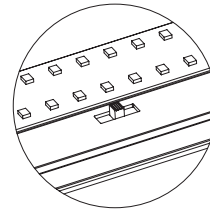

CCT switch

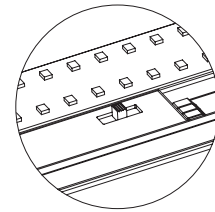

Power switch

Surface Mount

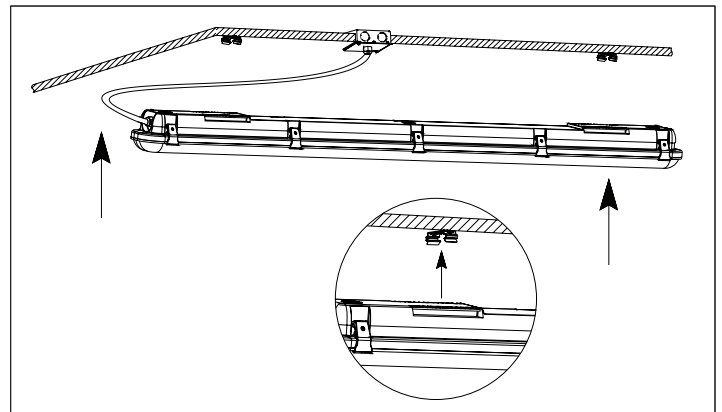
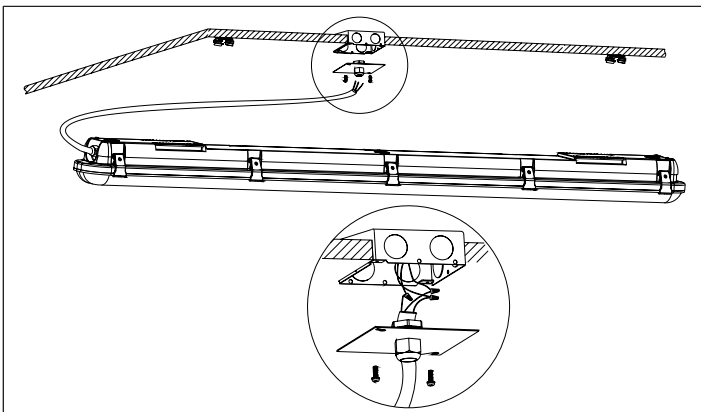
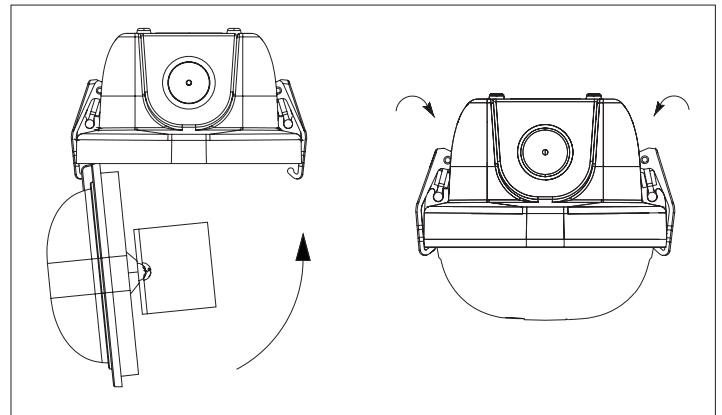
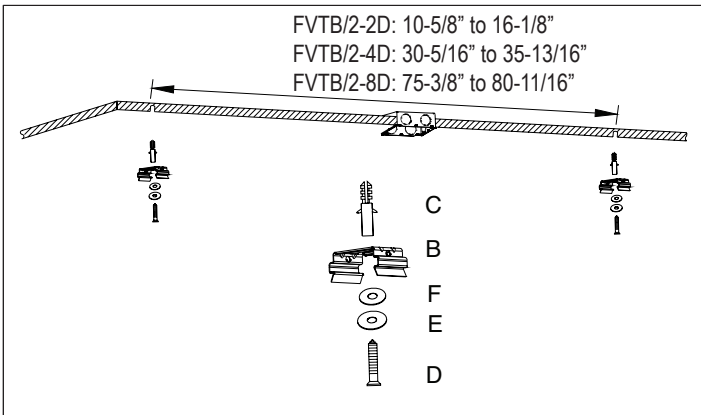
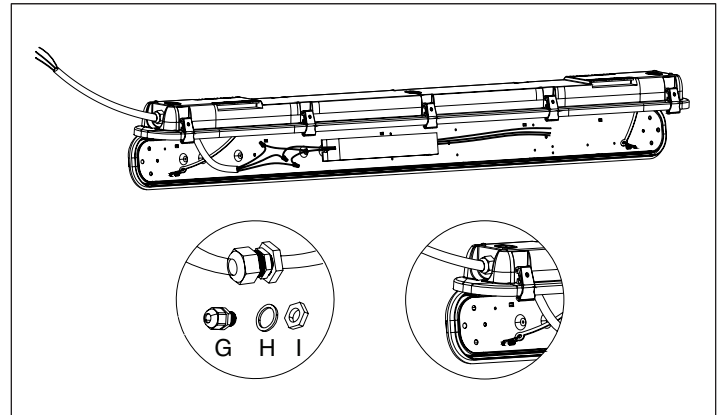
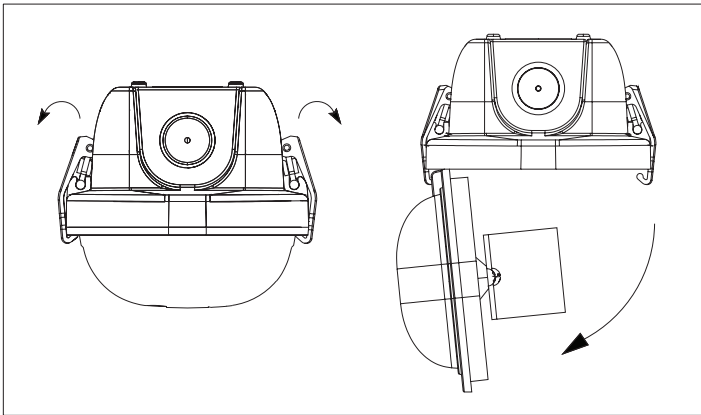

Suspension Mount

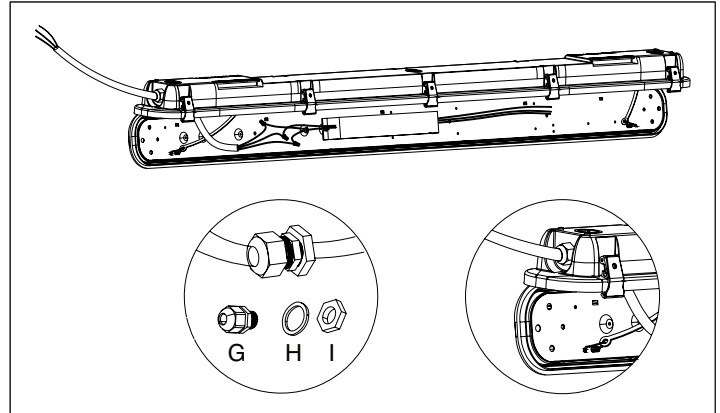
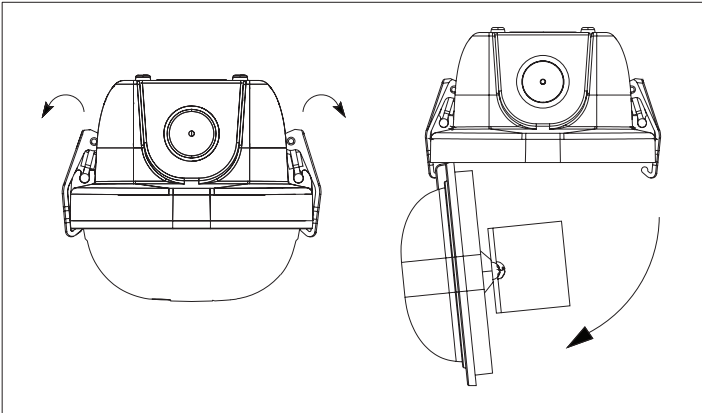

Chain Suspension Mount

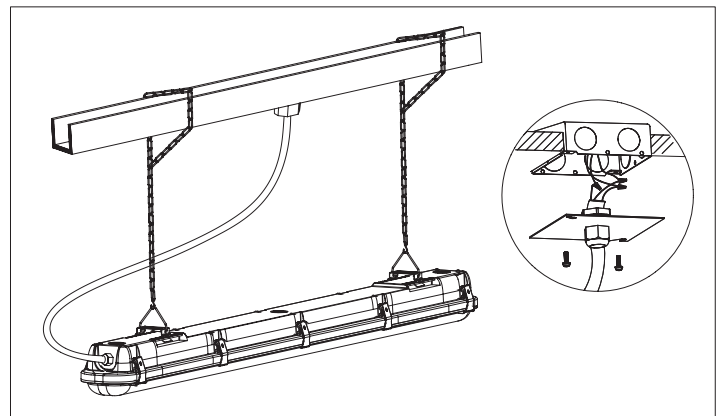
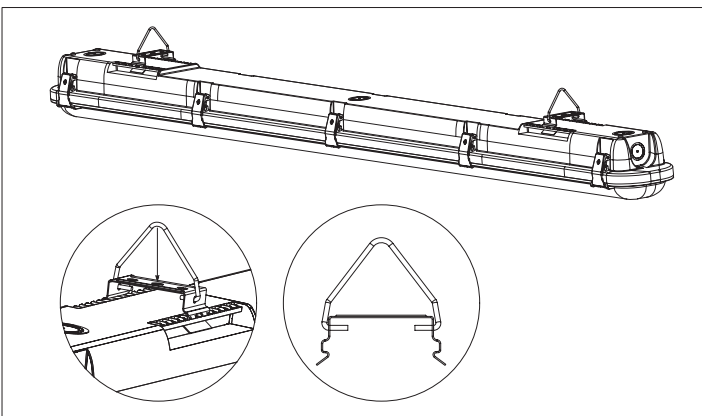

Cable Suspension Mount

