

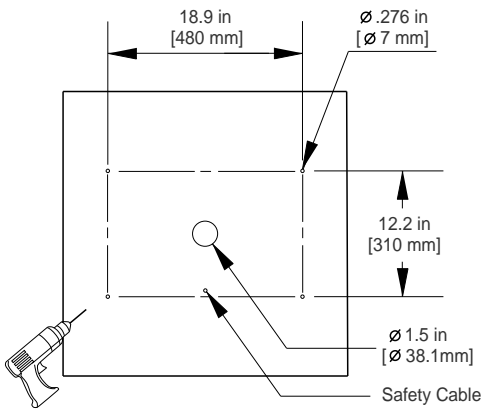

**CAUTION:** PLEASE FOLLOW THIS INSTRUCTION MANUAL CAREFULLY TO PREVENT ANY INJURIES OR COMPLICATIONS THAT MAY ARISE.  
**WARNING:** Before installing or maintaining the luminaire, make sure all powers are **TURNED OFF**.

1) Follow the Drilling Template Provided in Figure A. The four outer holes are to fasten the FCPA to the mounting surface where the luminaire will be getting placed. The Center hole is for the Center Hole of the luminaire, in order to run the cables from the luminaire through the conduit, into the J-Box, where all the wire connections will be made, included the AC Power Supply cables and the LED Driver wires.

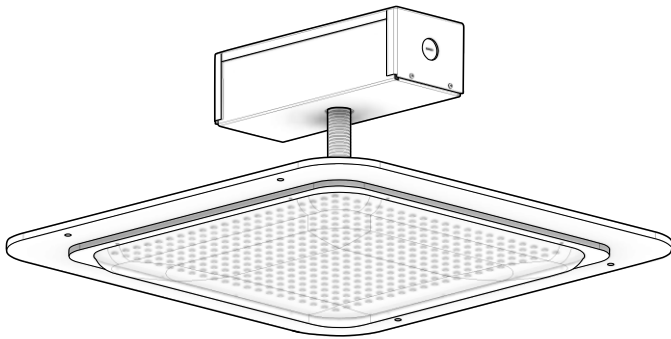

2) Use the four provided holes on the FCPA to fasten the Canopy Light to the ceiling. Have a qualified engineer check if the screws provided are appropriate for this luminaire under the mounting surface.



3) Access to the other side (above) of the ceiling in order to fasten the provided conduit to the FCPA from the center hole made in Step 1.

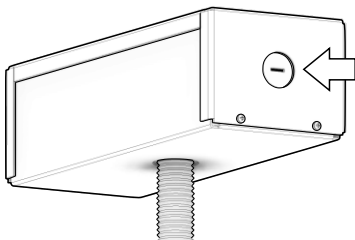
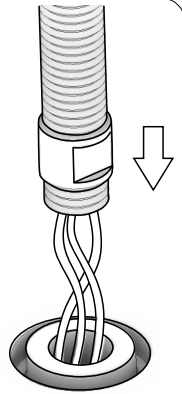

5a) Remove one of the conduit caps from the Junction Box in order to install a conduit with the AC Power Supply Cable.

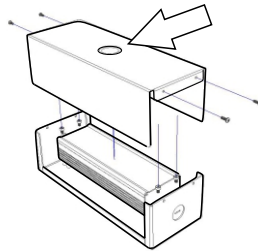

5b) Remove the small screw from the side of the Junction Box in order to access the LED Driver and properly wire the AC Power Supply to the LED Driver.

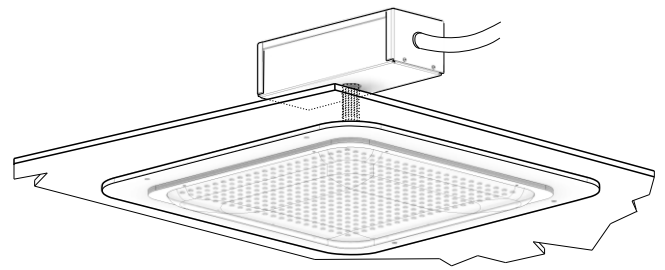

6) Once everything is properly installed, the FCPA would be mounted to the ceiling and all the wiring would be hidden inside the J-Box above the ceiling.

**WIRING DIAGRAM:** Connect the ACL and the ACN from the driver to the conduit with the AC Power Supply cords. Follow the Wiring Diagram provided.

