

## AC2SBAM1 ARM MOUNT (SQUARE POLE)

Includes: F2SB048, F2SB080, F2SB100, F2SB150, F2SB200, F2SB300

**CAUTION:** PLEASE FOLLOW THIS INSTRUCTION MANUAL CAREFULLY TO PREVENT ANY INJURIES OR COMPLICATIONS THAT MAY ARISE.

**WARNING:** Before installing or maintaining the luminaire, make sure all powers are **TURNED OFF**.

Verify that supply voltage is correct by comparing it with the label information on all fixtures.

Make all connections in accordance with the NEC requirements, and make sure all luminaires are properly secured to prevent any wire complications. This luminaire is to always be installed with the lens facing down and its not to exceed the maximum ambient temperature rating noted on the specification sheet.

### STANDARD INSTALLATION STEPS

#### DRILLING TEMPLATE

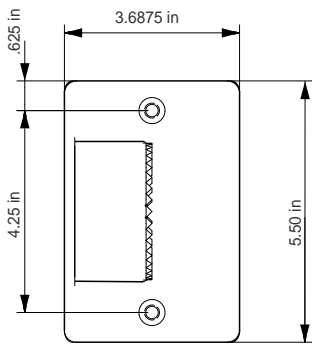

1. Use provided Hole Pattern for drilling. Make sure to make an extra notch for the power cables to run through the Round Tube.

2. Place mount against round tube.

3. Install the provided [2] Socket head M8-1.25 x 40 mm bolts with lock washer and washer to secure the arm mount firmly in place, insert the flat-bar with threaded holes inside the round tube and use the threaded holes to secure the mount. Make sure all bolts are tightened and holes are properly sealed.

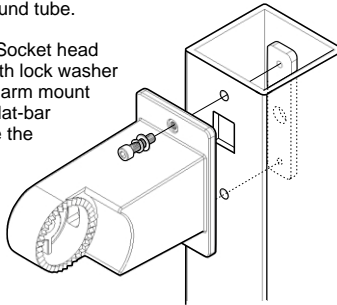

4. Once the Arm Mount is properly fastened to the mounting round pole, run the power cord cable from the inside of the pole and out the notch from the Arm Mount. This cable will then be inserted into the F2SB fixture.

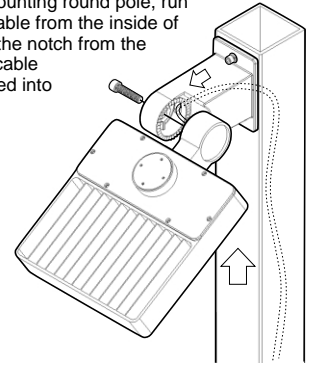

5. Run the power cord from the arm mount to the F2SB luminaire. Once the cable has been inserted inside the F2SB, connect the power cable to the LED Driver inside the F2SB. In order to access the LED Driver cables, the electrician must first remove the [6] screws from the service door using a #2 Phillips screw driver and make all connections inside the luminaire.

6. Once all wiring is complete, Close the service door and use the M12 bolt to fasten the Arm Mount to the F2SB. Do not fasten completely.

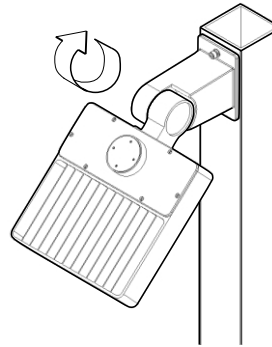
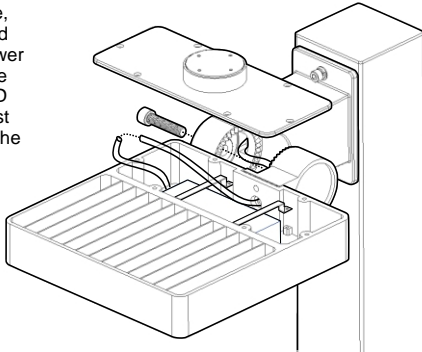

7. Adjust the Tilt Angle on the F2SB luminaire, once the Tilt Angle is as desired, finish tightening the Socket Head bolt to firmly tighten the F2SB with the Arm Mount.

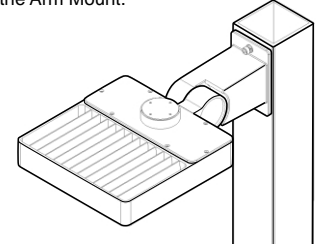

Using a J-Box (not included), Connect the ACL and the ACN from the driver to the conduit with the AC Power Supply cords. Follow the Wiring Diagram provided.



\* LED DRIVER Input Ground (green) wire only available for selected fixtures.

If the Ground Wire is missing and the Power Supply includes a ground wire, connect the power supply ground wire to the fixture.